



# Hippology Contest

---

- Description:** Teams share their knowledge and understanding of equine science and husbandry in a friendly but competitive setting. The Hippology Contest included four different phases; examination, station, judging and team problem.
- Entries:** May enter as individual or team of three to four members.
- State Awards:** First place individual and will receive registration assistance towards National Competition. They also receive the right to represent Utah at the Western National Contest in Denver.
- High individual will receive a Certificate of Recognition.
- National Awards:** Determined at the national level
- Sponsor:** Utah 4-H Horse Council

## General Information:

### 1. **Examination Phase** – approximately 200 points

This phase of the contest will include:

- a. Written Exam
- b. Projected slides to be identified as to breed, color, color pattern, activity, proper appointments, etc.
- c. Anatomy which may include external, skeleton, internal organs, parts of gastrointestinal tract, male and female reproductive organs, detailed anatomy of the foot and detailed lower limbs.

### 2. **Station Phase** – approximately 200 points

This phase will consist of a series of stations or tables where all contestants will respond to the requirements of the station. Members will be allowed two (2) minutes at each station. Examples of stations which may be used include:

- a. Identification of:
  - a. Various types of saddles (actual or pictures) and parts of saddles.
  - b. Tack, bits, bridles, horse shoes and parts of shoes. Tools and equipment, and assembly of specific parts of various pieces of equipment. Grains and forages used in equine rations including various forms of methods of preparation.
  - c. Internal and external parasites based on actual samples, pictures, life cycle charts and/or damage caused.
  - d. Blemishes and unsoundnesses.
  - e. Age of equines based on teeth.
- b. Use of pulse rate, respiration rate, temperature, dehydration, anemia, etc., to assess horse health.
- c. Measurements such as, but not limited to, wither height, shoe size, girth, collar size, gullet width, seat length of saddle, etc. may be required.

### 3. **Judging phase** – 200 points



In this portion of the contest, contestants will be required to place at least four (4) classes consisting of two (2) halter or conformation classes and two (2) performance classes. Every effort will be made to use the same horses as are being used in the judging contest, with the placing to be simultaneous with contestants in the judging contest, with the same official placings and cuts as apply to the judging contest. In extreme emergency, pictorial, video and/or classes may be used, in which case they would be especially prepared for the event.

4. **Team Problems** – approximately 200 points

In this portion of the contest each team will have equal time to discuss among themselves the problem, immediately after which they will have to present an oral solution or series of suggested procedures relative to the problem. Each member of each team is encouraged to contribute to the oral presentation. Evaluation will be based on the understanding of the problem, completeness of the response, the probability of success of the solution or procedures, and the logic used in making the oral response. The official may ask questions of any or all of the team members to clarify the presentation.

Examples of possible team problems might include:

- a. Balancing a horse's ration.
- b. Farm management recommendations for specific horse operations (i.e., breeding, training, boarding, nursery, lay-up, etc.).
- c. Considerations for the establishment of a new horse facility (stable to be used for a specific purpose).
- d. Recommendations for selecting, locating, and purchasing horses for specific uses.
- e. Behavior problems- causes, management of and corrections
- f. Training and conditioning programs – equipment, schedules, methods, nutrition, problem avoidance.
- g. Breeding and/or leasing contracts – specific clauses for insurance, liability, payments, care, termination, transport, etc.
- h. Teaching lessons in horse management (specific subject to be announced) to a group of 9-11 year old beginner 4-Her's: where, how long, how much information, hands-on experience, reinforcement, testing evaluation, will be considered.
- i. Explanation of use or assembly of specific equipment.
- j. Demonstrate skill or ability to use specific equipment.

Team problem scores will not be included in determining the rank of individuals in the contest, but will be added to the team scores of the other three phases to determine overall team standings.

### **Tie-Breaking**

All ties overall, individual and team, will be broken using the following sequence:

1. Examination scores
2. Station scores
3. Judging scores

Ties within any phase are to be broken using the overall score first and then the same sequence as above. If further tie breaking is needed, the scores at each station, in order may be used.

### **Awards**

1. Awards will be presented to the top ten (10) individuals in the Examination Phase, Station Phase, Judging Phase, and Overall.
2. Each member of the top ten (10) teams in the Examination Phase, Station Phase, Judging Phase, and in Overall will receive awards.



## Reference Material

---

All the information covered in this contest may be found in one or more of the following publications:

- IDET Illustrated Dictionary of Equine Terms – New Horizons Equine Education Center. Alpine Publications, PO Box 7027, Loveland, CO 80537  
Phone: (800) 777-7257
- Evans The Horse – Evans, Borton, Hintz, and Van Vleck. Second Edition. W. H. Freeman and Company, 660 Market Street, San Francisco, CA 94104  
Phone: (415) 391-5870
- Lewis Horse Industry Handbooks – Lon Lewis Williams and Wilkins. Second Edition. 351 West Camden Street, Baltimore, MD 21201-2436  
Phone: (800) 638-0672
- HIH Feeding and Care of the Horse – American Youth Horse Council; PRIMEDIA Equine, Attention: AYHC, 103 Pow Wow River Road, East Kingston, NH 03827 [http://www.ayhc.com/AYHC\\_Store.html](http://www.ayhc.com/AYHC_Store.html)  
Phone: (800) 952-5813
- YLM Youth Leaders Manual – American Youth Horse Council; PRIMEDIA Equine, Attention: AYHC, 103 Pow Wow River Road, East Kingston, NH 03827 [http://www.ayhc.com/AYHC\\_Store.html](http://www.ayhc.com/AYHC_Store.html)  
Phone: (800) 952-5813
- AQHA AQHA Rulebook: 2013 61<sup>st</sup> edition  
[www.aqha.com/handbook](http://www.aqha.com/handbook)  
Only show rules will be used (SHW300-SHW750; pages 118-241).
- Parker Equine Science – Rick Parker. Fourth edition. ISBN-13:9781111138776; Published January 2012
- USU Poisonous Plants and Equine.  
[https://extension.usu.edu/files/publications/factsheet/Equine\\_Brochure.pdf](https://extension.usu.edu/files/publications/factsheet/Equine_Brochure.pdf)
- Study the Equine Skeleton
- Grains, forages and feed preparations used in this contest will be representative of feeds utilized in horse rations.



# Anatomy & Physiology of the Horse

---

ANATOMY – Structure  
PHYSIOLOGY – Function

Nine (9) systems of the horse:

1. Skeletal – the bones and joints
2. Muscular
3. Respiratory
4. Circulatory
5. Digestive
6. Nervous
7. Endocrine
8. Reproductive
9. Integumentary

## SKELETAL SYSTEM

**Skeleton consists of:**

1. The trunk – skull, spinal column, ribs and breastbone
2. The limbs – legs

**Functions of the skeletal system:**

1. Provides a framework for the body
2. Supports soft tissue
3. Protects vital organs
4. Allows movement (in conjunction with the skeletal muscles) – acts as levers
5. Produces blood cells
6. Stores various inorganic salts such as sodium, calcium and phosphorus

**Skeletal system is made up of 205 bones:**

- |                                     |           |
|-------------------------------------|-----------|
| 1. Vertebral column .....           | 54 bones  |
| 2. Ribs .....                       | 36 bones  |
| 3. Sternum .....                    | 1 bone    |
| 4. Skull .....                      | 34 bones  |
| 5. Thoracic limbs (forelimbs) ..... | 40 bones  |
| 6. Pelvic limbs (hindlimbs) .....   | 40 bones  |
| Total .....                         | 205 bones |

## **BONES**

**Classification of bones:**

1. Long
2. Short
3. Flat
4. Irregular



# Circulatory System of the Horse

---

## Function of the cardiovascular system:

1. Perfuses the tissues of the body with blood
2. Transports nutrients and oxygen to every part of the body
3. Collecting waste products that are formed by the body tissue

Primary Function of the cardiovascular system is to move blood between the body cells and organs of the respiratory, digestive, urinary and integumentary systems.

## Classifications of the Circulatory System:

1. Systemic – responsible for moving blood through all parts of the body
2. Pulmonary – responsible for moving blood through lungs
3. Lymphatic – responsible for draining excess tissue fluid from all parts of the body

## Components of the Cardiovascular System

1. Heart
2. Arteries
3. Capillaries
4. Veins

## Heart

1. Acts as a pump which forces blood through the blood vessels
2. Consists of 4 chambers. Right and left atria (upper chambers), right and left ventricles (lower chambers)
3. Upper chambers are separated by a septum into right atrium and left atrium
4. Heart size is related to body size – average heart weight/body weight ration is 0.94%
5. Average heart rate is 35 beats per minute (32044 beats)
6. Cone shaped – located within the chest cavity between the left and right lungs and opposite the 3<sup>rd</sup>-6<sup>th</sup> ribs
7. Primary function of the heart is to propel blood by alternate muscular contraction (systole) and relaxation (diastole) throughout the circulatory system
  - V Valus open and let blood fall into the bentricle form the atria when the ventricles relax (diastole)
  - When the ventricles contract (systole) blood is forced against the A – V valves closing them

**Pulse-** continuous expansion of the atrial walls – can be felt externally

## Factors Influencing Heart Rate

1. Exercise
2. Physical condition
3. Environmental temperature
4. Excitement
5. Pathological conditions
6. Age

## Terms

Stroke Volume – quantity of blood ejected by the heart during each contraction (approx. 1 ltr)

Cardiac Output – quantity of blood pumped per minute (stroke volume x heart rate) approx. 35 ltrs



## Henneke Body Condition Scoring Sheet Chart

<b>Condition</b>	<b>Neck</b>	<b>Withers</b>	<b>Shoulder</b>	<b>Ribs</b>	<b>Loin</b>	<b>Tail Head</b>
<b>1 - Poor</b>	Bones easily noticeable	Bones easily noticeable	Structure of gone easily noticeable	Protruding prominently	Spinous processes project prominently	Bones protruding
<b>2 - Very Thin</b>	Can slightly see bones	Can slightly see bones	Can slightly see bones	Can see bones	Spinous process can see, some fat over spinous processes	Tail head prominent
<b>3 - Thin</b>	Neck can see bone shape	Can see wither shape	Can see bone shape	Some fats over ribs	Some fat on spinous processes	Tail head is prominent but cannot see bones
<b>4 – Moderately Thin</b>	Neck not noticeably thin				Bone appearance along back	Can be felt. Hook bones not noticeable
<b>5- Moderate Ideal Weight</b>	Neck smoothly blends into body	Rounded smoothly into body	Blends smoothly into body	Cannot see ribs, can be felt	Back is level	Fat around tail head, feel soft
<b>6 – Moderately Fleshy</b>	Fat starts to deposit	Fat starts to deposit	Fat starts to deposit	Fat feels spongy	Slight crease down back	Fat feels soft
<b>7 - Fleshy</b>	Fat along neck	Fat along neck	Fat behind shoulder	Ribs can be felt with pressure	May have crease down back	Fat around tail head
<b>8 - Fat</b>	Neck thickens	Wither area fills with fat	No definition behind shoulder and body	Hard to feel ribs	Crease down back	Fat around tail head soft
<b>9 – Extremely Fat</b>	Fat is largely noticeable	Fat is largely noticeable	Fat is largely noticeable	Fat is in patches over ribs	Big crease down back	Fat deposit is large at tail head



## Poisonous Plants

---

The potential for plant poisoning increases if horses have the opportunity to eat large quantities (Green plants in amounts equal to 5-10% of their body weight of a toxic plant over a period of several weeks or months. Rarely is a horse poisoned by a single mouthful of a plant with the EXCEPTION of the **MOST TOXIC OF PLANTS**; such as Water Hemlock and Yew.

### Factors that can change the toxic level of plants are:

- Drought, excessive moisture, fertilization and soil mineral imbalance.
- People can also be affected by poison plants through animals. If a cow eats a poisonous plant and then a human drinks the milk the poison can be passed on through the milk (White snakeroot.)
- Excessive Salivation:
  - Colic is the major clinical sign of these three
    - Laurel
    - Azalea
    - Buttercup
    -
  - Sudden death is the clinical sign of these three
    - Poison Hemlock
    - Water Hemlock
    - Death Camas
  - Neurologic-disease resulting in an inability to take in or chew feed are the major side effects of these two
    - Yellow star thistle
    - Russian Knapweed
  - Neurologic-disease resulting in an inability to take in or chew feed and muscle trembling are the major side effects of these four
    - White Snakeroot
    - Crofton weed
    - Jimmyweed (rayless goldenrod)
    - Burrow Weed

### Death minutes, 1-2 days

Larkspur, Monkshood, Choke Cherry, Sorghum grasses, Foxglove, Poison Hemlock, Water Hemlock, Milkweed, Oleander, Laurels, Rhododendron, Death camas, yews, Black Nightshade, Avocado

### Obstructions/Impaction of small and large intestines:

Fruits of plants of: Cockspur, Hawthorn, Mesquite, Persimmon

High amounts of OXALATE (causes stomach and intestinal inflammation and diarrhea): Halogeton, Greasewood, Shamrock, Soursob, Sorrel

Prolonged Consumption of low amounts of OXALATE from these plants may cause a calcium deficiency.

### Plants that can cause irritations, ulcers, lesions in the eyes and mouth:

Burdock Bristles, Three awn grasses. Oar awns, Sand burrs, Thistles, Foxtail, Barley awns, Prickly Pear Cactus, Bristle grasses (foxtail), Horse nettle, Buffalo Burr, Needle, Spear or Porcupine grass, Wheat Awns, Puncture vine, Goat head, Stinging Nettle, Cockle burrs.



# First Aid

---

## Open Wounds

1. incised wounds
2. Lacerations
3. Tears
4. Punctures
5. Penetrating wounds
6. Abrasions

## Incised Wounds

Clean, straight edges  
Bleed quite freely  
Heal quickly and simply  
(Cuts from metal, glass etc)

## Lacerations and Tears

Irregular in shape  
Bruising  
Tags (flaps of skin)  
Blood is compromised

## Death of Skin (Necrosis)

(Caused by protruding nails, posts, wire, etc)

## Puncture Wounds

Small skin opening, soft tissue penetration\  
(Bits, Pieces of Wire, Pitchfork)  
Hoofs (frog)  
Tetanus vaccination needs to be given  
Needs to be heal from the inside out – Poultice helps

## Abrasions

Superficial skin wounds  
(Rubbing or scraping)





## Treatment of Open Wounds

---

Involves damage skin, muscles, nerve, blood vessels, tendons, bones, internal organs

### **Infection:**

Goal in treatment

- Control hemorrhage

- Contaminated wound into a clean wound

- Promote healing rapidly

### **Hemorrhage:** Flush wound

- Large vessel: ligated – darker blood flows continuously

- Artery: bright red – will escape in spurts

- Pressure bandage: until bleeding stops, remove carefully

- Silver Nitrate: used to help stop bleeding

- Reconstituted cellulose help stop bleeding

- Absorbable gelatin sponges

  - Clean with water then a mild antiseptic of:

  - 1% iodine-based washed, Providone Iodine, Chlorhexidine



# Horseshoe Diagram

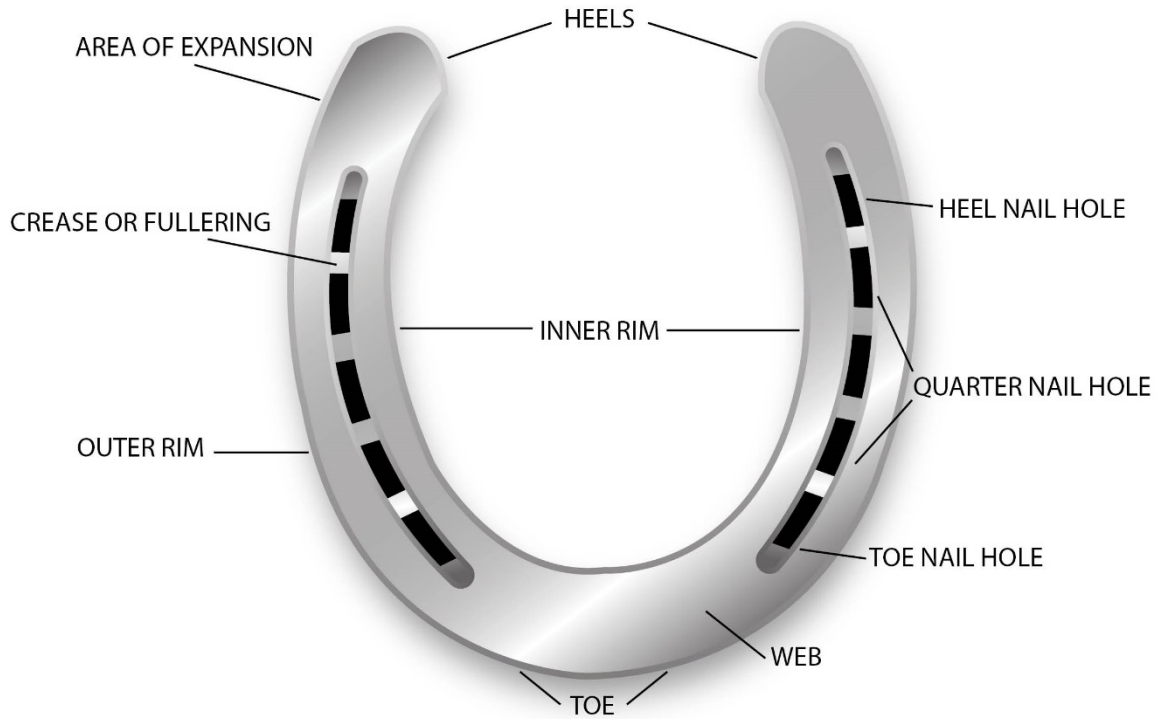

# Horseshoe Nail

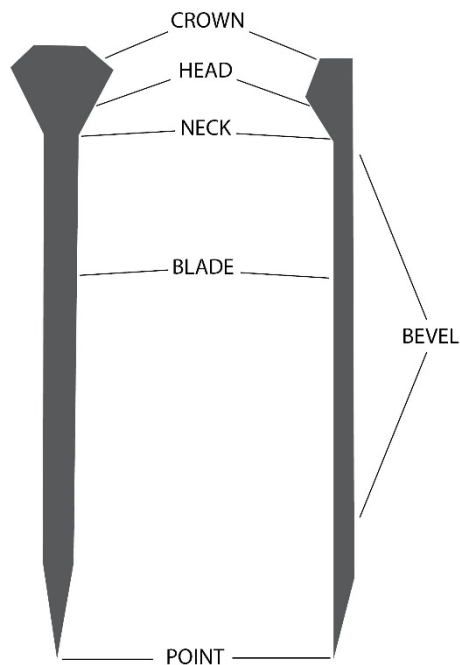

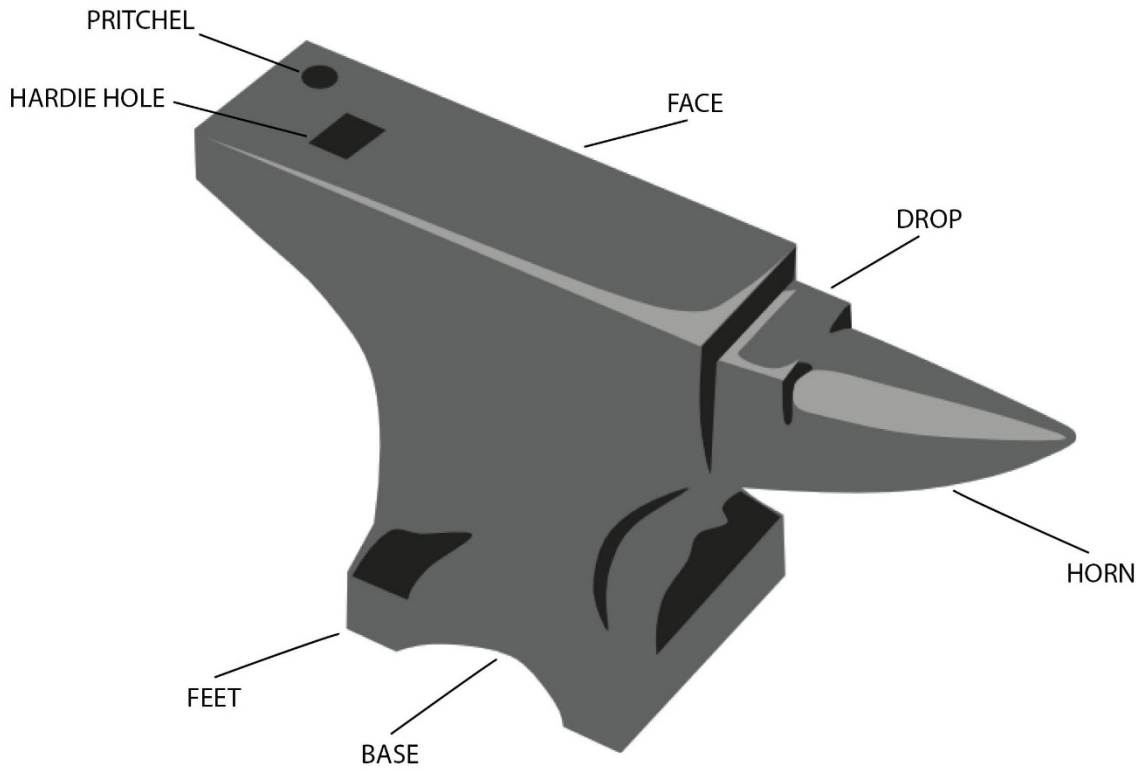



# Hippology Scorecard

<b>Blue Ribbon?</b> (Circle One) <b>Yes</b> <b>No</b>
--

Team ID# \_\_\_\_\_  
 Name \_\_\_\_\_  
 County \_\_\_\_\_

	Team Member Number				Max Points	Score
	1	2	3	4		
<b>GENERAL APPEARANCE:</b> Appropriate dress, visible distractions					4	
<b>DELIVERY:</b> Eye contact, gestures, enthusiasm Pronunciation and enunciation					8	
					8	
<b>LANGUAGE EFFECTIVENESS:</b> Skill in using meaningful & appropriate					4	
<b>ORGANIZATION OF CONTENTS:</b> 1. Introductory statement of key points 2. Sequence of key points 3. Body – development of key points 4. Summary of key points					10	
					10	
					10	
					10	
<b>OVERALL QUALITY:</b> Appropriate topic coverage, originality					16	
					20	
Total Points					100	

Judges' comments and statement supporting score:

\*Team member numbers 1, 2, 3, 4 used for marking each individual's contribution in presentation.

Team consists of at least 3 members.

Revised 2/1992, 12/2002



# Hippology Stations- Answer Sheet

Name: \_\_\_\_\_

County: \_\_\_\_\_

<p><b><u>STATION 1</u></b></p> <p>1 _____</p> <p>2 _____</p> <p>3 _____</p> <p>4 _____</p> <p>5 _____</p> <p>6 _____</p> <p>7 _____</p> <p>8 _____</p> <p>9 _____</p> <p>10 _____</p> <p>SCORE: _____</p>	<p><b><u>STATION 1</u></b></p> <p>1 _____</p> <p>2 _____</p> <p>3 _____</p> <p>4 _____</p> <p>5 _____</p> <p>6 _____</p> <p>7 _____</p> <p>8 _____</p> <p>9 _____</p> <p>10 _____</p> <p>SCORE: _____</p>	<p><b><u>STATION 1</u></b></p> <p>1 _____</p> <p>2 _____</p> <p>3 _____</p> <p>4 _____</p> <p>5 _____</p> <p>6 _____</p> <p>7 _____</p> <p>8 _____</p> <p>9 _____</p> <p>10 _____</p> <p>SCORE: _____</p>	<p><b><u>STATION 4</u></b></p> <p>1 _____</p> <p>2 _____</p> <p>3 _____</p> <p>4 _____</p> <p>5 _____</p> <p>6 _____</p> <p>7 _____</p> <p>8 _____</p> <p>9 _____</p> <p>10 _____</p> <p>SCORE: _____</p>	<p><b><u>STATION 5</u></b></p> <p>1 _____</p> <p>2 _____</p> <p>3 _____</p> <p>4 _____</p> <p>5 _____</p> <p>6 _____</p> <p>7 _____</p> <p>8 _____</p> <p>9 _____</p> <p>10 _____</p> <p>SCORE: _____</p>
---	---	---	---	---

<p><b><u>STATION 6</u></b></p> <p>1 _____</p> <p>2 _____</p> <p>3 _____</p> <p>4 _____</p> <p>5 _____</p> <p>6 _____</p> <p>7 _____</p> <p>8 _____</p> <p>9 _____</p> <p>10 _____</p> <p>SCORE: _____</p>	<p><b><u>STATION 7</u></b></p> <p>1 _____</p> <p>2 _____</p> <p>3 _____</p> <p>4 _____</p> <p>5 _____</p> <p>6 _____</p> <p>7 _____</p> <p>8 _____</p> <p>9 _____</p> <p>10 _____</p> <p>SCORE: _____</p>	<p><b><u>STATION 8</u></b></p> <p>1 _____</p> <p>2 _____</p> <p>3 _____</p> <p>4 _____</p> <p>5 _____</p> <p>6 _____</p> <p>7 _____</p> <p>8 _____</p> <p>9 _____</p> <p>10 _____</p> <p>SCORE: _____</p>	<p><b><u>STATION 9</u></b></p> <p>1 _____</p> <p>2 _____</p> <p>3 _____</p> <p>4 _____</p> <p>5 _____</p> <p>6 _____</p> <p>7 _____</p> <p>8 _____</p> <p>9 _____</p> <p>10 _____</p> <p>SCORE: _____</p>	<p><b><u>STATION 10</u></b></p> <p>1 _____</p> <p>2 _____</p> <p>3 _____</p> <p>4 _____</p> <p>5 _____</p> <p>6 _____</p> <p>7 _____</p> <p>8 _____</p> <p>9 _____</p> <p>10 _____</p> <p>SCORE: _____</p>
---	---	---	---	--



# Junior Hippology

Name: \_\_\_\_\_

### Fill in the blank

1. Main, tail and legs black or darker than the rest of the body is called? \_\_\_\_\_ hh4
2. A white strip covering the coronet band is called? \_\_\_\_\_ hh7
3. The back of the saddle behind the seat is called? \_\_\_\_\_ hh27
4. The wooden or metal frame of a saddle is called? \_\_\_\_\_ hh29
5. This piece of equipment is used to help control the height of the horse's head, what is it called?  
\_\_\_\_\_ hh34
6. A race without jumps is called? \_\_\_\_\_ hh40
7. A farrier is called? \_\_\_\_\_ hh47
8. A healthy hoof grows \_\_\_\_\_ to \_\_\_\_\_ per month. hh47
9. This results when a horse travels in a manner inconsistent with its natural way of going is called?  
\_\_\_\_\_ hh50
10. The offspring of a sire is called? \_\_\_\_\_ hh56

### Multiple Choice

11. Chestnuts are also known as:  

A. Night Eyes	B. Moon Eyes	C. Ergot	D. Hoof	hh8
---------------	--------------	----------	---------	-----
12. A horse that holds its head too high and its nose out is called?  

A. Paunchy	B. Star Gazer	C. Crest	D. Moon Watcher	hh9
------------	---------------	----------	-----------------	-----
13. Thin, sharp, arched back is called?  

A. Beetle Back	B. Bug Back	C. Roach Back	D. Razor Back	hh9
----------------	-------------	---------------	---------------	-----
14. A slow, natural flatfooted, four beat gait is called?  

A. Fox Trot	B. Canter	C. Pace	D. Walk	hh16
-------------	-----------	---------	---------	------
15. Art of riding the horse and of understanding its needs is called?  

A. Equitation	B. Horsemanship	C. Appointments	D. Aids	hh22
---------------	-----------------	-----------------	---------	------
16. That part of hackamore that fits over and around the nose is called?  

A. Noseband	B. Cavesson	C. Bitting Rig	D. Bosal	hh27
-------------	-------------	----------------	----------	------
17. Use \_\_\_\_\_ to trim off the horn of the hoof.  

A. Nippers	B. Rasp	C. Clinchers	D. Hammer	hh47
------------	---------	--------------	-----------	------
18. This is a bruise of the sole at the angle of the wall and the bar of the hoof:



- A. Ringbone                      B. Gravel                      C. Founder                      D. Corn                      hh50
19. A horse of Eastern or Oriental blood is called?
- A. Part-Bred                      B. Hot-blooded                      C. Cold-blooded                      D. Crossbred                      hh56
20. Native to the Shetland Isles of Scotland is:
- A. Quarter Horse                      B. Welsh Pony                      C. Miniature Horse                      D. Shetland Pony                      hh58

### Matching

21. \_\_\_\_\_ is golden color, varying from bright copper to light yellow
22. \_\_\_\_\_ designates a small, clearly defined area of white hairs on the forehead
23. \_\_\_\_\_ when a rider's reaction to a horse's gait are pleasant and enjoyable
24. \_\_\_\_\_ a western saddle with cinch hung from center
- A. Center fire
- B. Easy gaited
- C. Star
- D. Palomino
- E. Snip
- F. Free going
- G. Chestnut